



Genetically Optimized Pre coders Transceiver Design for Double STBC System

K.N.V.Satyanarayana¹, D.V.R.Mohan², B.H.K.Bhagat Kumar³

K.N.V.Satyanarayana¹ M.Tech Scholar, Dept of ECE, S.R.K.R Engg.college Bhimavaram

D.V.R.Mohan², Prof, Dept. of ECE, S.R.K.R.Engg.college Bhimavaram

B.H.K.Bhagat Kumar³, Asst Prof, Dept of ECE, SAI ADITYA ENGG COLLEGE, Surampalem

s.kanuboina@gmail.com

Dvr-mohan2001@yahoo.com

bhagat4kumar@gmail.com

Abstract

Wireless communications depends on multiple-input-multiple-output (MIMO) techniques for high data rates. Feedback of channel information can be used in precoding to use the strongest channel mode and improve MIMO performance. The DPC system is interference free on multi-user or multi-antenna. The STBC transceiver can provide the transmit diversity. Due to the benefits about the STBC and DPC system, we propose a new scheme called STBC-DPC system. The transceiver design involves the following procedures. First, the ordering QR decomposition of channel matrix and the maximum likelihood (ML) one-dimensional searching algorithm are proposed to acquire a reliable performance. Next, the channel on/off assignment using water filling algorithm is proposed to overcome the deep fading channel problem. Finally, the STBC-DPC system with the modulus operation to limit the transmit signal level, i.e., Tomlinson-Harashima precoding (THP) scheme, is proposed to retain low peak-to-average power ratio (PAPR) performance. Simulation results confirm that the proposed STBC-DPC/THP with water filling ML algorithm can provide the low PAPR and excellent bit error rate (BER) performances.

Keywords—*Orthogonal space-time block coding (OSTBC), dirty paper coding (DPC), Tomlinson-Harashima precoding (THP), peak-to-average power ratio (PAPR), maximum likelihood decision (MLD).*

I. INTRODUCTION

The primary concern in configuration of wireless communication lies in the domains of spectral efficiency and link reliability [1]. Multiple antennas at transmitter

and receiver ends of MIMO technology are capable to cope with these issues in future wireless communication systems. Multiple views of received signals enhance the robustness due to employment of Diverse Multipath Fading algorithm. Spatial diversity improves the channel reliability in pre-defined resources and transmission time but at the expense of high transmission power [2].

In order to overcome the interference problem and reduce the computational loading for mobile user, we want to study the precoding technique at base station, which can pre-equalize or pre-cancel the spatial interference at base station. It is well known that the dirty paper coding (DPC) [6] uses precoding technique [7] to eliminate inter-symbol interference (ISI) on single user or multi-users interference. Moreover, due to the DPC with interference free and low complexity benefits, we propose the joint processing for double STBC and DPC (STBC-DPC) precoding techniques to acquire the spatial diversity and multiplexing gains. To the best of our knowledge, there is no publication paper proposed joint double STBC and DPC precoding techniques for MIMO downlink systems.

In this research, the MIMO STBC transceiver structure with four transmitter antennas and two receiver antennas is studied. First, the bit error rate (BER) performances of the ZF and MMSE equalizers at receiver site are considered as a benchmark for our proposed system. Next, to reduce the complexity at receiver, the STBC-DPC precoding technique is proposed to achieve the low complexity benefit for mobile station. Besides, to improve the performance of the proposed STBC-DPC system, the ordering QR decomposition of channel matrix and the ML searching algorithm are proposed for the sequential one-dimensional symbol detection. It can achieve a reliable BER performance. However, the ML algorithm cannot overcome the problem of the deep fading channel. In order to combat the problem, the channel on/off assignment using water filling algorithm is proposed. It is obvious to enhance the system performance. Finally, it is well known

that the precoding technique will conduct high PAPR problem. The STBC-DPC system with the modulus operation to limit the transmit signal level, i.e., Tomlinson-Harashima precoding (THP) scheme [8], is proposed to constrain high peak power and retain low peak-to-average power ratio (PAPR) performance. Simulation results reveal that the proposed STBC-DPC/THP with water filling ML algorithm can offer the low PAPR and excellent BER performances.

II. STBC AND DPC SIGNALMODEL

In this section, we will introduce the STBC and DPC systems. Then the drawback and benefit of the two systems will be investigated. First, for Alamouti's STBC system, 2-transmit antennas and 1-receiver antenna are used to achieve transmit diversity. That is, in time slot 1, antenna-1 and antenna-2 transmit signal x_1 and x_2 and time slot 2 transmit signal $-x_2^*$ and $-x_1^*$, respectively. The received signal is given by

$$[y_1 \ y_2] = [h_1 \ h_2] \begin{bmatrix} x_1 & -x_2^* \\ x_2 & -x_1^* \end{bmatrix} + [n_1 \ n_2]. \quad (1)$$

The transmitted signal can be detected by

$$[\hat{x}_1 \ \hat{x}_2]^T = \mathbf{H}^H [y_1 \ y_2]^T = (\mathbf{H}^H \mathbf{H}) [x_1 \ x_2]^T + [\tilde{n}_1 \ \tilde{n}_2]^T, \quad (2)$$

where $\mathbf{H} = \begin{bmatrix} h_1 & h_2 \\ h_2^* & -h_1^* \end{bmatrix}$ with $\mathbf{H}^H \mathbf{H} = \text{diag} \{ |h_1|^2 + |h_2|^2, |h_1|^2 + |h_2|^2 \}$.

As shown in (2), we can find that the diagonal term of (HH) matrix has the transmit diversity. Next, the dirty paper coding system uses the concept of precoding.

It involves two characteristics, i.e., interference free and lower receiver complexity. The system structure is shown as follow. In Fig. 1, the system is assumed by 2_2 MMO system, where the transmitted signal can be expressed as

$$\begin{bmatrix} x_1 \\ x_2 \end{bmatrix} = \begin{bmatrix} r_{11} & r_{12} \\ 0 & r_{22} \end{bmatrix}^{-1} \begin{bmatrix} r_{11} & 0 \\ 0 & r_{22} \end{bmatrix} \begin{bmatrix} \tilde{x}_1 \\ \tilde{x}_2 \end{bmatrix}, \quad (3)$$

$$\mathbf{R} = \begin{bmatrix} r_{11} & r_{12} \\ 0 & r_{22} \end{bmatrix} \quad \mathbf{R}_{diag} = \begin{bmatrix} r_{11} & 0 \\ 0 & r_{22} \end{bmatrix}. \quad (4)$$

After DPC precoding, the original signal $1 \ x_ , 2 \ x_$ can be transmitted by x_1 and x_2 . Referring to Fig. 1, the received signal y_1, y_2 can be given by

$$\begin{bmatrix} y_1 \\ y_2 \end{bmatrix} = \mathbf{Q}^H \mathbf{H} \begin{bmatrix} x_1 \\ x_2 \end{bmatrix} + \begin{bmatrix} n_1 \\ n_2 \end{bmatrix}. \quad (5)$$

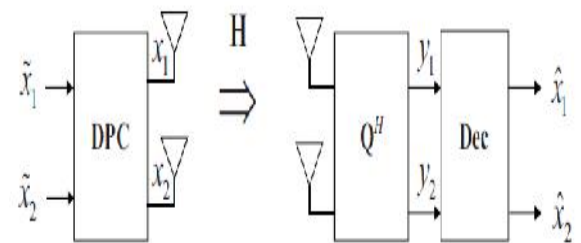

Fig. 1. Transceiver structure of dirty paper coding

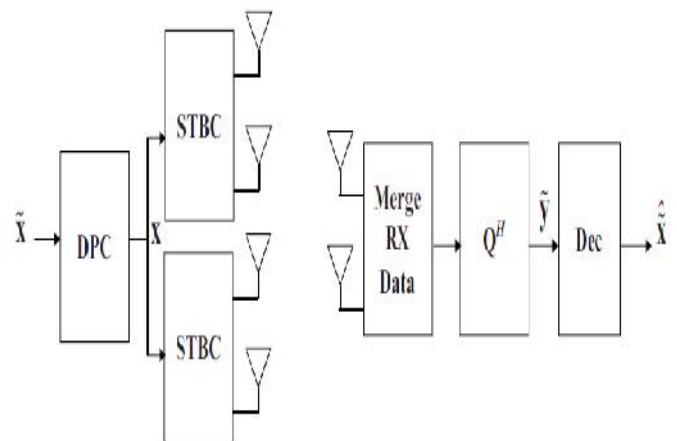

Fig. 2. STBC-DPC system transceiver block diagram

Due to the benefits of STBC and DPC systems, we try to propose a precoding STBC system to attain better BER performance.

III. NEW DOUBLE STBC DPC PRECODING

It is well known that the double STBC system can dual advantages, i.e., transmit diversity gain and high data rate. However, the double streams interference will occur. Next, due to the DPC with interference free and low complexity benefits, the joint STBC-DPC precoding technique can be proposed to acquire the spatial diversity and multiplexing gains.

IV. PROPOSED METHOD

Motivated by the linear theoretical spectral efficiency improvement using multiple antenna at the both ends from the radio link, enormous efforts were made to design for the transmission schemes for MIMO systems. Two major techniques emerged: spatial multiplexing and space-time coding. While spatial multiplexing transmits multiple independent data streams from different antennas simultaneously, space-time coding achieves full diversity gain without the knowledge of fading channel at the transmitter. The use of multiple antennas has been a recent significant breakthrough in wireless technologies. It creates a MIMO channel in which each path.

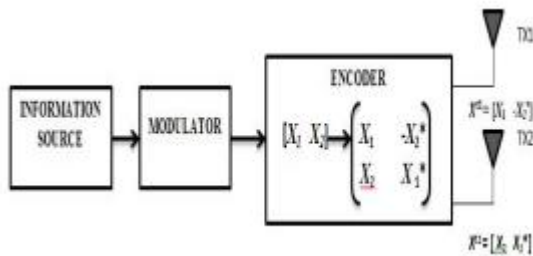

Fig.3. STBC Encoder

The important feature of the Alamouti scheme is shown in equation antennas, since the inner product of the sequences x_1 and x_2 is zero, i.e.

$$x_1^{t1} \cdot x_2^{t2} = x_1 x_2^* - x_2^* x_1$$

the code matrix has the following property:

$$X \cdot X^H = \begin{bmatrix} |x_1|^2 + |x_2|^2 & 0 \\ 0 & |x_1|^2 + |x_2|^2 \end{bmatrix} = (|x_1|^2 + |x_2|^2) I_2$$

where I_2 is a 2 X 2 identity matrix. At the receive antenna, the received signals over two consecutive symbol periods, denoted by r_1 and r_2 for time t and $t + T$, respectively, can be expressed as

$$r_1 = h_1 x_1 + h_2 x_2 + n_1$$

$$r_2 = -h_1 x_2^* + h_2 x_1^* + n_2$$

where n_1 and n_2 are independent complex variables with zero mean and power spectral density $N_0/2$ per dimension, representing additive white Gaussian noise samples at time t and $t + T$ respectively.

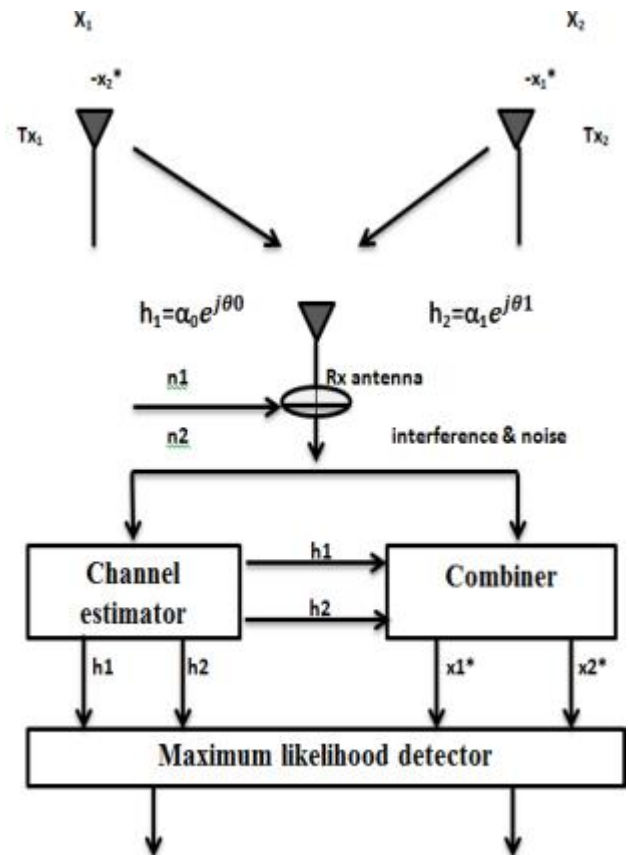

Fig.4. STBC Decoder

Tomlinson-Harashima Precoding (THP)

It is well known that the precoding technique will induce the high PAPR problem. In this section, we want to study the TH precoding technique to reduce PAPR. In [9], the TH precoding technique was invented for reducing the peak-to-average power ratio in the DFE processing. Next, due to DPC scheme conducting transmit signal variation, the modulus operation, i.e., THP, is proposed to use for the DPC signal and retain the transmitted signal power. Fig. 3 is shown the block diagram of STBC-DPC/THP system.

V. RESULTS

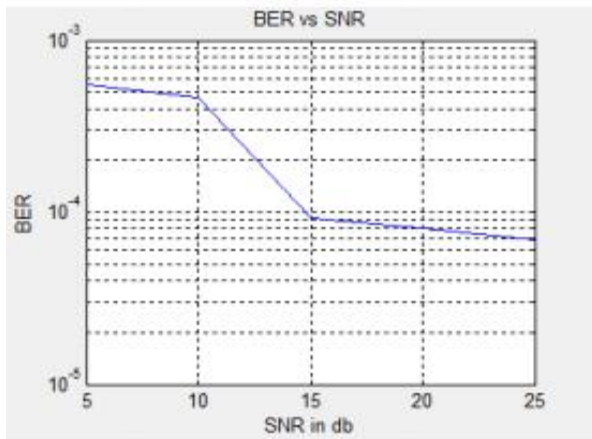

Fig.5.SNR vsBER for MIMO OFDM Using V BLAST

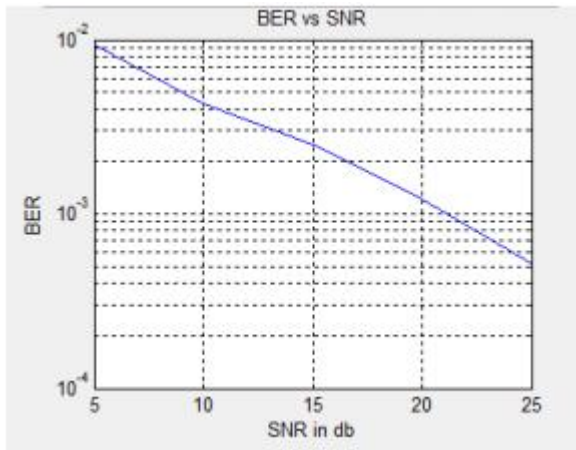

Fig.6.SNR vsBER for MIMO OFDM Using STBC

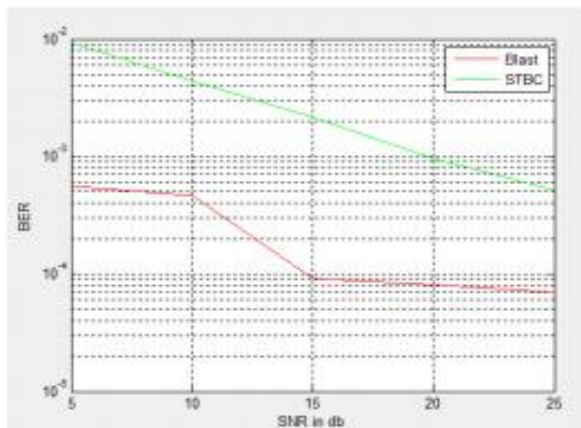

Fig.7.Comparison of SNR vs BER for Both MIMO OFDM Using STBC

In V-Blast we can Observe that for channel BER is about 10^{-3} communication because the data is transmitted independently through different channel

therefore time required is less to transmit the data the only disadvantage of this system is BER because at receiver side the data is weak due to fading effect. Therefore the choice of this system is depend on user. In STBC based system as shown in fig 5. the BER is 10 for 4 channel.

We can conclude that BER is improve because in this system we have send multiple copies of data through different antenna at receiver side using MLD decoding we will get our data with less error. But in this system at same time we are sending same copies of data therefore the data transfer rate of this system is not so good.

Now we can conclude from fig 6. that by considering BER as parameter that STBC system is good for error less transmission but if we require high speed transmission we will consider V-BLAST for that. require high speed transmission we will consider V-BLAST for that.

Scheme	Spectral Efficiency	P_e	Implementation Complexity
V-BLAST	HIGH	HIGH	LOW
STBC	LOW	LOW	LOW

Table 1. V-BLAST V/S STBC

VI.CONCLUSION

In the present work, the techniques that are V-Blast and STBC has been implemented in MIMO-OFDM systems and the performance has been evaluated on the basis of Bit error rate. The modulation used is BPSK modulation. From the results it has been concluded that for high data rate V-blast is preferred technique while for bit error rate STBC is preferred for the wireless communications.

Results showing that BER for MIMO system is less with optimized precoder that rotating precoder. This idea also can be used with multiuser MIMO system to improve performance.

By using high order antenna configuration space diversity can be increased, which will further decrease the

BER at given SNR as compared to lower order Antenna configurations. By doing so, even higher data capacity at any given SNR can be achieve

REFERENCES

[1] L. J. Cimini, "Analysis and simulation of a digital mobile channel using orthogonal frequency division multiplexing", IEEE Transaction on Communications, Vol. 33, Issue 7, pp. 665–675, July 1985.

[2] Part 11: Wireless LAN Medium Access Control (MAC) and Physical Layer (PHY) Specifications: High-Speed Physical Layer in the 5 GHz Band, IEEE Standard 802.11a- 1999.

[3] P. W. Wolniansky, G. J. Foschini, G. D. Golden and R. A. Valenzuela, "V-Blast: An architecture for realizing very high data rates over the rich-scattering channel", International Symposium on Signals, Systems and Electronics, pp. 295–300, 1998.

[4] W. A. C. Fernando, R.M.A.P. Rajatheva and K. M. Ahmed, "Performance of Coded OFDM with Higher Modulation Schemes", International Conference on Communication Technology, Vol. 2, pp 1-5, 1998.

[5] PAULRAJ A , NABAR R , GORE D . Introduction to space-time wireless communication [M]. Cambridge: Cambridge University Press, 2003.

[6] SUTO K, OHTSUKI T. Space Time Frequency Block Codes over Frequency Selective Fading Channels[J]. 2004.