

# Novel Repetitive Control Technique for Three Phase Four Wire Shunt Active Power Filter

<sup>1</sup>Kedarisetty Bhargava Ravi Kanth, <sup>2</sup>D Tatarao, <sup>3</sup>K Manoz Kumar Reddy

M.Tech Student, Department of EEE, Aditya College of Engineering, Surampalem, AP, India.<sup>1</sup>

Asso. Professor, Department of EEE, Aditya College of Engineering, Surampalem, AP, India.<sup>2</sup>

Asso. Professor&HOD, Department of EEE, Aditya College of Engineering, Surampalem, AP, India.<sup>3</sup>

Corresponding Author- \*bharumbts1994@gmail.com

**Abstract-** This paper presents a discrete dreary control procedure for three stage four wire (3P4W) shunt enthusiastic force channel (SEPF). By and large, the control plan for power gadgets includes two control circles: slow acting external voltage circle and speedy performing inside current control circle. The reference for inward current circle is occasional in climate and can't be basically followed by PI controller. The dreary regulators (RC) are notable for their following capacity of occasional sign and deal high addition at every one of the frequencies. The high increase in higher recurrence reach might lead towards unsteadiness. Hence, in proposed work, the standard RC is changed by square its affectability work. Fluffy rationale regulator is utilized in this task to improve the force quality. This methodology brings about low sufficiency of affectability work while offering profound indents at low to mid frequencies range and more modest scores at high frequencies. This control approach has been reproduced and execute on 3P4W SAPF.

Key words—Repetitive Control, Active Power channel, symphonious pay, Power Quality, 3P4W, Load Compensation, Non-direct burden, Unbalanced Load, Fuzzy rationale regulator.

## I. INTRODUCTION

The force framework network at dispersion level faces a great deal of sorts of challenge, fundamentally identified with load unbalance, receptive force and current sounds and so on From power framework administrator's place of perception, these kind of issues should be address at dispersion level itself so age and transmission could perform effectively with no aggravation. routinely, the electro mechanical gadgets like tap evolving transformer, detached channel, and coordinated condenser have been used to figure out the issues identified with power quality. Nonetheless,

with the development of complex force gadgets ability, part of custom force gadgets like unique voltage restorer (DVR), dynamic force channels (APF) might be series or shunt type, static compensator (STATCOM), brought together force quality regulator (UPQC) are broadly being utilized to alleviate power quality difficulty. By and large, voltage or current managed voltage source inverter is use as series or shunt associated gadget relying upon circumstance. The SAPF is extra desirable over take care of burden current related issues, where it tends to be controlled to supply the heap current music, unbalance and responsive current interest with the goal that matrix side current consistently stay adjusted arrangement of sinusoidal current at solidarity power factor (UPF).

Since, SAPF is current controlled gadget, where the inward current control circles are a whole lot sooner than external sluggish voltage circles, it turns into a common arrangement inconvenience to foster a quick reacting regulator. besides, the internal current signs to be dealt with are occasional in nature and they need to changed into comparable DC signals to manage them utilizing simple PI regulator. Along these lines, the presentation of regulator relies upon the precision of change which is profoundly delicate to variety in recurrence and stage point. A major number of control procedures for inward current circle of SAPF have recently been proposed. Greater part of them are generally founded on PI, corresponding full (PR), hysteresis, lack of involvement based control (PBC) and loser (DB) regulators. Here, PI is the easiest one yet can't be utilized for swaying signal, hysteresis regulator might reason reverberation issue because of variable exchanging recurrence, the PR can be tuned distinctly for specific sounds, PBC and DB require exact model of framework and control execution might endure with boundary varieties. Some man-made consciousness based control methods have likewise been accounted for



Here, it is worthwhile to declare that the 4th leg of SAPF is utilized to supply the neutral load current demand (unbalance current component) so that the grid side neutral current could be limited to zero. This also indicates the balanced operation of grid. Let us consider a non-linear unbalance load drawing a complex power:

$$S = P + jQ = \bar{P} + \tilde{P} + j(\bar{Q} + \tilde{Q}) \quad (1)$$

The SAPF infused flows can be control by controlling its terminal voltage, stage point and the impedance. This demanding target can be accomplished by exchanging the force hardware switches so that the SAPF's impedance and burden impedance turns out to be simply resistive burden to be provided from matrix. Accordingly, the exchanging grouping of different switches in SAPF structures the functioning rule of burden pay. The activity of SAPF can be controlled use external voltage and inward current control circles. The current control circles have especially fast elements in similitude to slow acting voltage control circle. The fundamental point of voltage control circle is to direct the dc-connect capacitor voltage which by implication sets the reference for dynamic force needed by APF to meet out its exchanging misfortunes. The PI controller is utilized to follow the mistake between real (Vdc) and reference (Vdc) dc-connect voltages. The yield of PI controller sets the reference of dynamic current part (id). Since, the APF is controlled in backhanded control mode, the receptive current part (intelligence level) is set to nothing. The lattice synchronizing point ( $\theta$ ) got from stage lock circle (PLL) is used to decide the network side reference flows ( $i_a^*$ ,  $i_b^*$ , and  $i_c^*$ ). To have lattice side adjusted activity, the unbiased reference current ( $i_n^*$ ) is set to nothing. The genuine matrix side flows are contrasted and the foreordained reference flows, where the proposed tedious regulator tracks the mistake flows to zero worth. The total schematic with

control description is shown in Fig.2.2.

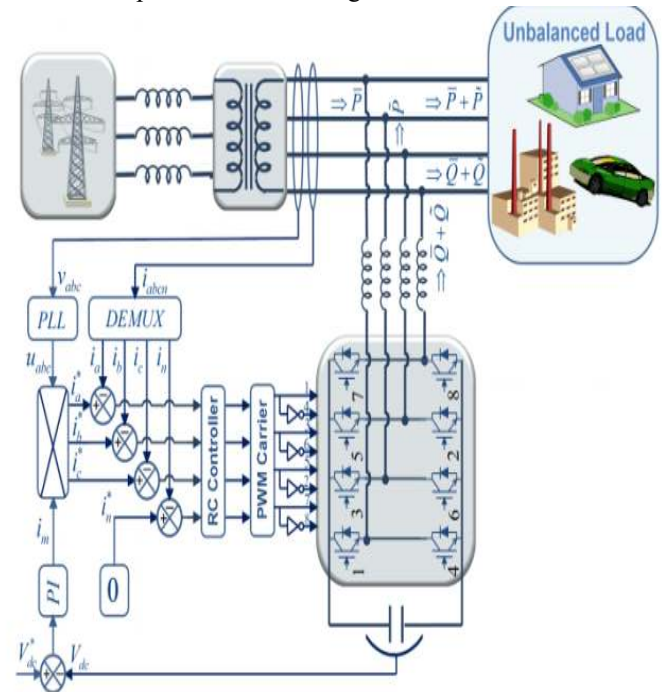

Fig. 2.2. Control Description of 3P4W Shunt Active Power Filter.

## II. Control Description:

The control of network associated power electronic converters includes abc-dq change generally known as Park's change which depends on pivoting reference outline hypothesis. The basic benefit of this specific change is that it brings about semi DC signals which are not difficult to follow. The improvement of control framework for a basic resistive-inductive burden is exceptionally basic and can be handily controlled utilizing a low transfer speed relative indispensable (PI) regulator.

## III REPETITIVE CONTROLLER DESIGN:

The tedious regulators are generally used to take care of those control issues where the unsettling influences or motions toward be controlled are intermittent with characterized time spans. As indicated by IMPT, a generator with intermittent sign should be remembered for regulator input circle to follow the occasional reference signal. The intermittent sign generator use huge time postpone

terms comparing to times of reference signal. In genuine practice, a zero-stage FIR low pass channel  $H(z)$  is utilized to lessen the addition of those frequencies where the exhibition of framework isn't well clear. Here, it is appropriate to specify that this FIR low pass channel diminishes the increase of regulator to limited qualities for every one of the frequencies and consequently takes the state of ordinary low pass channel  $q(z, z^{-1})$ . A regular tedious regulator with zero-stage blunder low pass channel is displayed in Fig. 2.3.

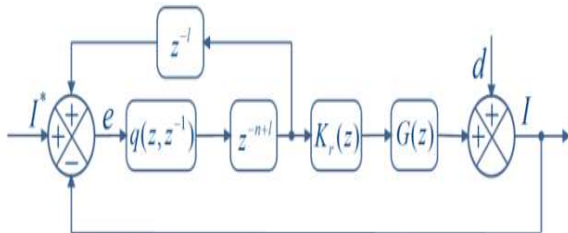

Fig. 2.3. Structure of Typical Repetitive Controller.

Here, the main objective of this particular controller is to achieve smaller magnitude of sensitivity function at the fundamental frequencies.

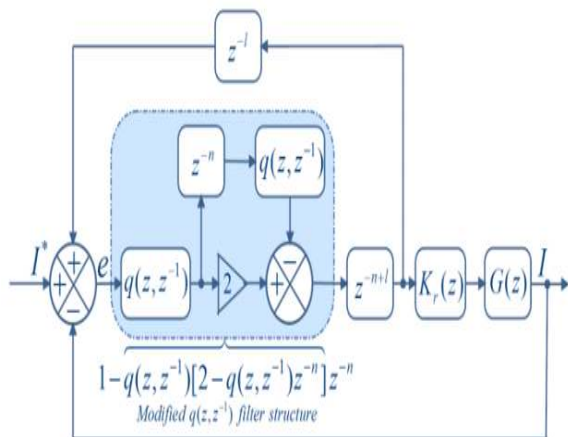

Fig. 2.4 Structure of Modified Repetitive Controller.

#### IV.FUZZY LOGIC CONTROL

FLC dictated by the arrangement of etymological guidelines. The numerical demonstrating isn't needed in fluffy regulator because of the change of mathematical variable into phonetic factors. FLC comprises of three section: a. Fuzzification, b. Obstruction motor, c. Defuzzification. The fluffy regulator is portrayed as; For each info and yield there are seven fluffy sets. For straightforwardness a participation capacities is Triangular. Fuzzification is utilizing constant universe of talk. Suggestion is

utilizing Mamdani's "min" administrator. Defuzzification is utilizing the "centroid" strategy.

#### IV. Recreation Block Diagram:

The proposed framework is mimicked utilizing the different modules of MATLAB/Simulink SimPower System tool compartment. A 4-leg inverter isn't promptly accessible in Simulink library. In this way, the 8 no. of IGBT's have been taken to frame a current controlled voltage source converter, where it is associated in corresponding with burden to go about as SAPF. The driver circuit for individual IGBT is additionally evolved in Simulink itself. The singular switches of SAPF are controlled to acquire the 3-stage adjusted arrangement of central matrix flows at solidarity power factor with their particular framework stage voltages in spite of exceptionally unequal non-direct burden associated at purpose in like manner coupling (PCC) under fluctuating burden conditions. An unbalance 3-stage 4-wire non-straight factor load is reenacted utilizing both single stage just as 3-stage load with rectifier, resistive and inductive burden profile.

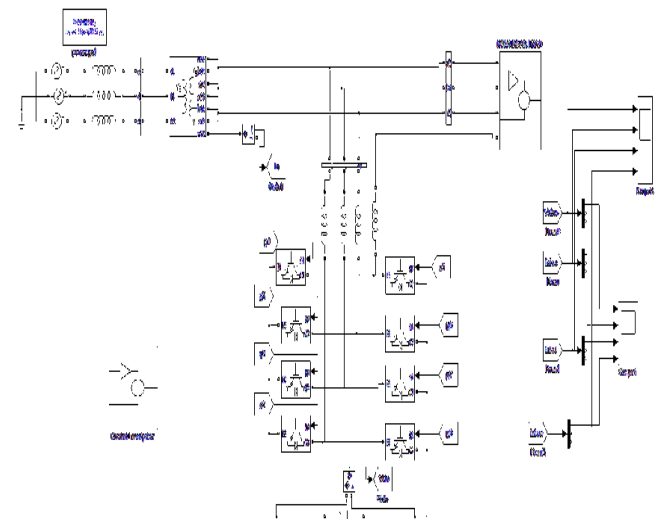

FIG4.1:Simulink Block Diagram

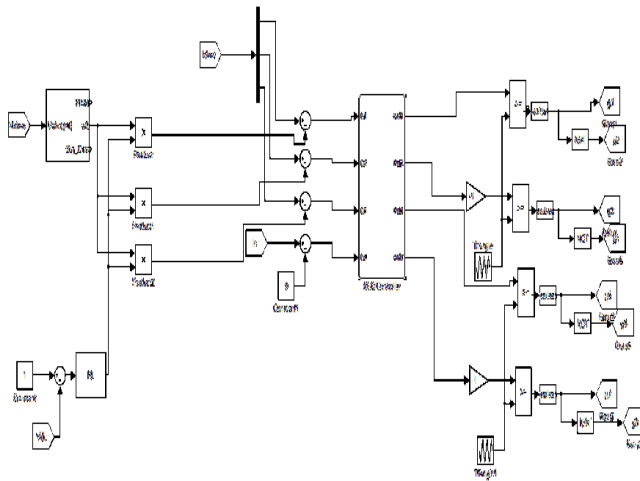

Fig4.2: Control Block Diagram

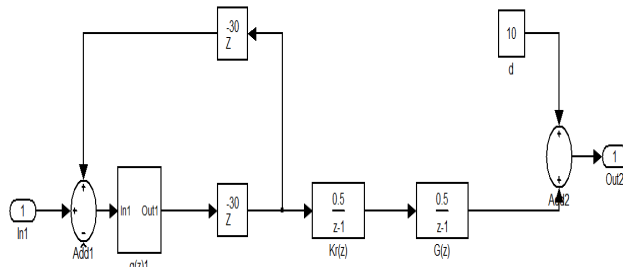

Fig4.3: RC Controller

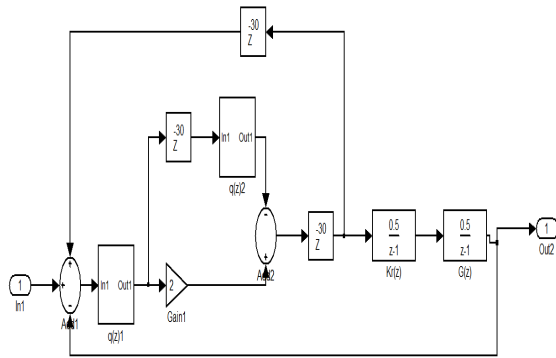

Fig4.4: Modified RC Controller

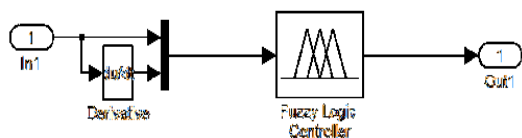

Fig4.5: Fuzzy Logic Controller Controller

**Simulation Results:**

The simulation results comprising the waveforms of grid side voltage (VG), grid side current (IG), unbalanced load side current (IL) and injected SAPP currents (IAPF) are shown in Fig.. Here, it is worthwhile to mention that the simulation study has been carried out with two different controllers on same system with same parameters for the comparison purpose. The Fig. 4.6 shows the simulation results with the RC controller as used in our previous work .

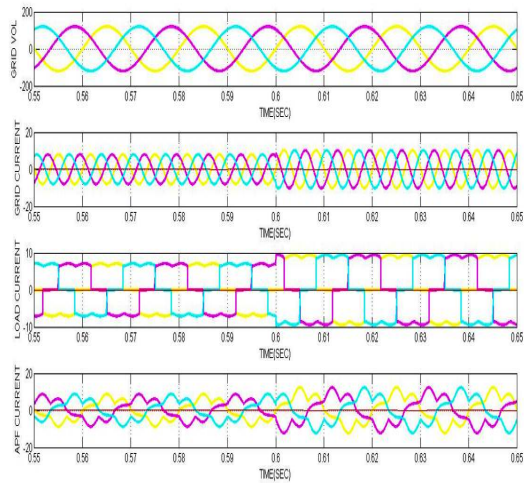
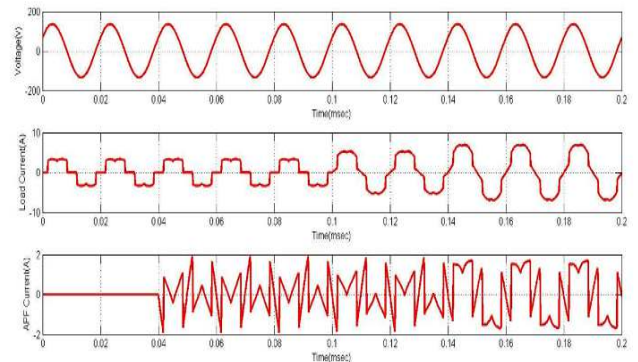

Fig. 4.6 Simulation results with RC: (a) Grid side voltages, (b) Grid side currents, (c) Unbalanced load side currents, (d) APF currents.

This shows the simulation results with proposed RC controller. On carefully analyzing the load current waveforms, it can be observed that initially, a three phase balanced nonlinear rectifier load is connected in the system. At  $t = 0.6$  sec, the non-linear load is suddenly increased by 75% of its initial loading and again at  $t = 0.8$  sec., the load is reduced to its initial value. At  $t = 1.0$  sec, a RL load is connected to the phase A of supply.



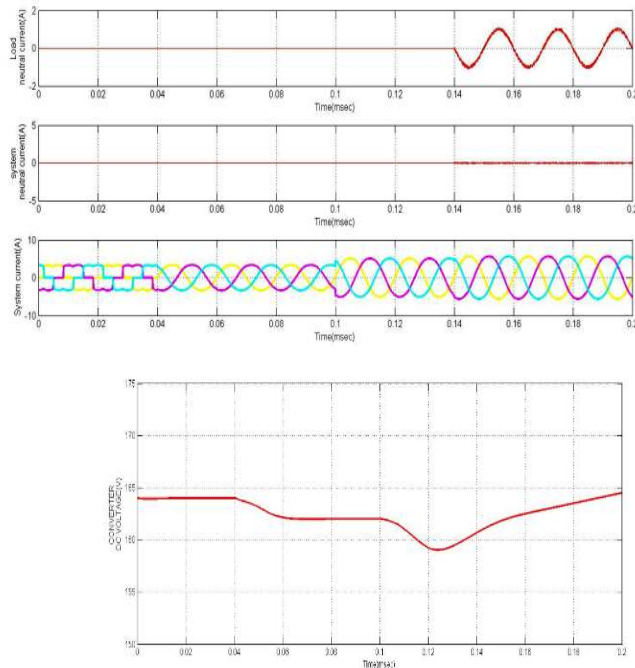

Fig. 4.7. Mimicked waveforms of the proposed Fuzzy control. (a) Phase to unbiased source voltage. (b) Load Current. (c) Active force channel yield current. (d) Load unbiased current. (e) System unbiased current. (f) System flows. (g) DC voltage converter.

End

An altered RC regulator displaying, plan and reenactment for the control of SAPF have been introduced in this paper. From the plan and displaying planned, it has been exhibited that the changed RC regulator has preferable control data transmission over traditional RC. The proposed regulator gives agreeable outcomes under the powerful working conditions. It has additionally been exhibited that the SAPF can deal with the non-straight burden request both under adjusted and unequal conditions. To approve these realities, recreations results are given. Fluffy rationale regulator is utilized in this paper. At last, the broad reenactment results have likewise been introduced to help the cases. Here, it very well may be seen that the current sounds, current unbalance and responsive current interest of burden are repaid so that the lattice side flows are constantly kept up with as a 3-stage adjusted

arrangement of central current at UPF. Also, the heap unbiased current interest is provided locally from the fourth leg of SAPF with the goal that the lattice side impartial current could be restricted to zero worth.

## REFERENCES

- [1] Pablo Acuña, Luis Morán, Marco Rivera, Juan Dixon, and Jos'e Rodriguez, "Improved Active Power Filter Performance for Renewable Power Generation Systems," *IEEE Trans. Power Electronics.*, vol. 29, no. 2, pp. 687–694, Feb. 2014.
- [2] M. Aredes, J. Hafner, and K. Heumann, "Three-phase four-wire shunt active filter control strategies," *IEEE Trans. Power Electron.*, vol. 12, no. 2, pp. 311–318, Mar. 1997.
- [3] H. Akagi, "New trends in active filters for power conditioning," *Ind. Appl. IEEE Trans. On*, vol. 32, no. 6, pp. 1312–1322, 1996.
- [4] C. Lascu, L. Asiminoaei, I. Boldea, I. Boldea and F. Blaabjerg, "High performance current controller for selective harmonic compensation in active power filters," *IEEE Trans. Power Electron.*, vol. 22, no. 5, 1826-1835, Sep. 2007.
- [5] Q. N. Trinh and H. H. Lee, "An advanced current control strategy for three-phase shunt active power filters," *IEEE Trans. Ind. Electron.*, vol. 60, no. 12, pp. 5400-5410, Dec. 2014.
- [6] Y. Suresh, A. K. Panda and M. Suresh, "Real-time implementation of adaptive fuzzy hysteresis-band current control technique for shunt active power filter," *IET Power Electron.* vol. 5, no. 7, pp. 1188-1195, 2012.
- [7] L. Wang, C. S. Lam, M. C. Wong, N. Y. Dai, K. W. Lao and C. K. Wong, "Non-linear adaptive hysteresis band pulse-width modulation control for hybrid active power filters to reduce switching loss," *IET Power Electron.*, vol. 8, no. 11, pp. 2156-2167, Nov. 2015.
- [8] F. Briz, P. Garcá, M. W. Degner, D. Daíz-Reigosa and J. M. Guerrero, "Dynamic behavior of current controllers for selective harmonic compensation in three-phase active power filters," *IEEE Trans. Ind. Appl.*, vol. 49, no. 3, pp. 1411-1420, May-Jun. 2013.
- [9] C. Lascu, L. Asiminoaei, I. Boldea and F. Blaabjerg, "Frequency response analysis of current controllers for selective harmonic compensation in active power filters," *IEEE Trans. Ind. Electron.*, vol. 56, no. 2, pp. 337-347, Feb. 2009.

- [10] D. D. Puerto-Flores, J. M. A. Scherpen, M. Liserre, M. M. D. Vries, M. J. Kransse and V. G. Monopoli, "Passivity-based control by series/parallel damping of single-phase PWM voltage source converter," *IEEE Trans. Control Syst. Technol.*, vol.22, no. 4, pp. 1310-1322, Jul. 2014.
- [11] Y. Gui, W. Kim and C. C. Chung. "Passivity-based control with nonlinear damping for type 2 STATCOM systems," *IEEE Trans. Power System.*, vol. 31, no. 4, pp. 2824-2833, Jul. 2016.
- [12] Y. Han, L. Xu, M. M. Khan, C. Chen, G. Yao and L. D. Zhou, "Robust deadbeat control scheme for a hybrid APF with resetting filter and ADALINE-based harmonic estimation algorithm," *IEEE Trans. Ind. Electron.*, vol. 58, no. 9, pp. 3893-3904, Sep. 2011.
- [13] M. Singh, and A. Chandra, "Real Time Implementation of ANFIS Control for Renewable Interfacing Inverter in 3P4W Distribution Network," *IEEE Trans. Industrial Electron*, vol. 60, no.1, pp. 121-128, Jan. 2013.
- [14] M. Qasin, P. Kanjiya, and V . Khadkikar, "Artificial-neuralnetworkbased phase-locking scheme for active power filters," *IEEE Trans. Power Electron.*, vol. 61, pp. 3857 – 3866, Aug. 2014.
- [15] A. Trivedi, and M. Singh, "Repetitive Controller for VSIs in Droop Based AC-Microgrid," *IEEE Trans. Power Electronics*, Vol. 32, No. 8, pp. 6595-6604, Aug.-2017.
- [16] Qingzeng Yan, Xiaojie Wu, X. Yuan, and Y. Geng, "An Improved Grid Voltage Feedforward Strategy for High-Power Three-Phase Grid Connected Inverters Based on the Simplified Repetitive Predictor," *IEEE Trans. Power Electronics*, Vol. 31, No. 5, pp. 3880-3897, May. 2016.