

PV Fed BLDC Driven Water Pumping System With MPPT Technique Employing Zeta Converter

M V Suresh Kumar¹, K Anusha², M Shyam Kumar³, J Sai Sudheer⁴, P Venkatesh⁵

¹Asso. Professor Department of EEE, Raghu Engg. College, Visakhapatnam, A.P, India.
^{2,3,4,5}B.Tech, Students Department of EEE, Raghu Engg. College, Visakhapatnam A.P, India.

ABSTRACT

Renewable sources will be increase in value through automotive sector even by usage of a brushless DC (BLDC) driven photovoltaic (PV) pumping systems. The power transfer and address the downside associated with traditional DC-DC converters are being improved by usage of zeta converter. By monitoring the zeta converter operating period via the PSO-based Maximum Power Point Tracking Algorithm, optimum power is derived from either the solar array. That hybrid energy storage system (HESS), which preserves the constant voltage at the input of BLDC generator, PV framework for the reduction of PV performance volatility will be implemented. By using a robust power management algorithm PV-HESS will be properly controlled. That complete MPPT power management allows its Zeta converter simple for both the water pumping device to achieve smooth efficiency. While comparing other methods of MPPT technique, INC-conductance based MPPT technique is best because it provides better results for randomly varying atmospheric conditions. The control system's output is displayed with MATLAB/SIMULINK allowing atmospheric variance.

Keywords—Brushless DC (BLDC) motor; hybrid energy storage system (HESS), maximum power point tracking

INTRODUCTION

For scientists, renewable energy sources are becoming increasingly important as demand for electricity grows worldwide. Solar electricity, which is safe and environmentally benign, is among the most popular renewable sources of energy in existence today. No, because solar energy is irregular, does it need a full power point that could monitor the production of the solar electricity system. Various MPPT algorithms are discussed in the literature [1] for keeping track of the solar PV system's potential power output. Traditional MPPT methods include P&O (perturb and observe), INC (incremental conductance), short circuit current, and open circuit voltage. MPPT technology[2]

continues to be developed in order to overcome the limits of contemporary algorithms. In a PV network, a non-uniform solar separation (PSC) is known due of the rain, the colours of trees and homes.

It is possible for PSC to produce numerous peaks in the PV characteristics. The local peak, which is not the MPPT of P-V functionality, can be connected to the regular MPPT algorithms. It has been one of the most recent and efficient MPPT techniques for maximum energy extraction from either the solar photovoltaic device using a PSO-dependent MPPT algorithm [3]. Backup and energy storage devices are included in the solar pv supply to maintain its output. Batteries and supercapacitors can be combined to create a hybrid energy storage system. Because of this, the battery and super condenser give both the steady state and enough power to help intermittent circumstances.

HESS can either load or unload a bidirectional DC-DC converter. The DC-DC converter changing pulses for the two-way will be produced based on the correct power management algorithm. That's why we've stuck with the bidirectional buck-boost converter. The DC-DC converter raises the PV's output voltage. As a result, the literature provides many DC-DC converter topologies, one of which, the zeta converter, merits researchers' attention because it may be employed in many applications such as MPPT, power factor correction (PFC), and increased power efficiency [4]-[6]. There is no limit to the maximum power point tracking (MPPT) area, unlike conventional buck and boost converters[7]. Inductor existence on the output side induces constant and free ripple power output, and c) some negative voltage-sensing components exist with the zeta-converter, because it generates non-inverted output voltages.

Because of its gentle starting[8] and efficiency as a water pump, the BLDC motor is an excellent choice. A PSO-based MPPT algorithm is employed to produce switching pulses for both the zeta converter and an

algorithm for dual circuit power management in this project [9,10].

II DESCRIPTION OF THE SYSTEM

Figure 1.1 shows a PV-HESS piping system controlled by a BLDC motor for use with an MPPT algorithm based on PSO.

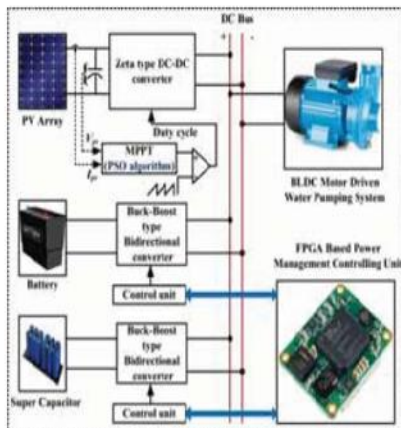

Fig.1.1: Hybrid PV-ESS fed BLDC motor driven water pumping system.

BLDC and HESS-driven solar pv systems have been employed as a primary source of water pumping systems for controlling intermittent system reaction to changes in atmospheric conditions. The zeta converter activated the pulses generated by the PSO-based MPPT controller. As a result, the battery and super condenser are in charge of managing the device's power under a variety of environmental conditions. While in a stable state, your battery acts as a giant capacitor, absorbing voltage fluctuations. Continuous voltage across the whole BLDC engine, regardless of the surrounding atmosphere, is the ultimate goal.

Specifically, the MPPT algorithm is being used for PSO-oriented management of the PV-HESS device to provide switching pulses for the zeta converter, which is why stand-alone water pump systems are recommended. Real-time energy management systems are tested with a fuzzy logic unit. The PI controller switch improves network stability when used on the DC-DC transformer.

THREE STATEMENTS OF INTERVENTION INTO CONTROL

A single, powerful water pumping equipment requires the operation of DC-DC electricity converters. The symmetric DC-DC converters are monitored using a

dual loop power storage technique, while the PSO-MPPT model powers the zeta converter to find full power from PV devices.

Application of the PSO Algorithm to MPP Tracking PSO [12] was found to be particularly effective in terms of power device issue optimization, electronics applications, harmonical energy harvesting converters [13], etc. Genetic, intestinal, and other biological algorithms necessitate several parametric calculations. While many other biological optimization computations are complex and time-consuming, PSO is straightforward to implement. PSO particles go through the question's space, consider the best answer, and store it in the brain. The highest level of community and systemic health is referred to as the highest level of individual benefit and the highest level of global interest. This process repeats itself over and over again until the best professional and worldwide principles have been updated at a predetermined rate. The particle's speed and location were changed in the following ways

$$\begin{aligned} \phi_{id}(k+1) &= \phi_{ij}(k) + c_1 r_1 [P_{bij}(k) - \rho_{ij}(k)] + \\ & c_2 r_2 [P_{gij}(k) - \rho_{ij}(k)] \\ \rho_{ij}(k+1) &= \rho_{ij}(k) + \phi_{ij}(k+1) \end{aligned} \quad (1)$$

where $i = 1, 2, \dots, n$; $j = 1, 2, \dots, d$; k is the recapitulation number then $k+1$ index means the next repetition. c_1 and c_2 are the rushing coefficients consistent to personality weight then sociality weight correspondingly (both are taken as 2.05 in this article), consistently circulated random quantity between $[0, 1]$. ρ_{ij} is the individual best practice of separately particle, ϕ_{ij}

is the greatest particle in the group found so remote it signifies the location and velocity of i^{th} particle correspondingly.

$$\chi = \frac{2}{|2 - \varphi - \sqrt{\varphi^2 - 4\varphi}|}, \varphi = c_1 + c_2 \text{ and } \varphi > 4$$

$$\begin{aligned} \phi_{id}(k+1) &= \chi [\phi_{ij}(k) + c_1 r_1 (P_{bij}(k) - \rho_{ij}(k)) + \\ & c_2 r_2 (P_{gij}(k) - \rho_{ij}(k))] \end{aligned} \quad (2)$$

Based on the MATLAB setting, the MPPT-based PSO technology is applied to determine both the optimal operating cycle and optimize control. The

MPPT regulates the V_{pv} & I_{pv} via sensors and calculates power production. The process begins with such a random selection of the velocity as well as the particles throughout the minimal to full service period (operation period of both the Zeta converter). MPPT was known as its fitness function (FF).

$$FF = \max P_{PV}(D) \quad (3)$$

It is possible to serve for a length of time that ranges from zero to one duty period. Due to the last review, it has been determined that the service time and minimum workout values for the national and global jobs are the same. At the following algorithmic level, the entire swarm's timing, position, and location are all altered, but (4). The changed particle location was not exactly the same as the prior one due to the stochastic existence of PSO. High voltage would be generated when this occurs too frequently in D.

For the sake of efficiency, the dc voltage is ranked by the most recently obtained value and the shortest duty cycle is also selected. There will be no more iterations until the counter has been incremented more than the predetermined number of times. The performance factor will be used to reevaluate the repetition rate. The swarm's particles were reset to match the observed shading sequence. Five particles in the code are the maximum number of iterations that can be performed. Controlling global maximum output during the standard and selective shading of both PV collection is efficiently achieved by the suggested MPPT controller.

Algorithm INC-MPPT Version 3.2

For a smooth start of a BLDC motor and to maximise the strength available from an SPV array, the popular and widely used INC-MPPT technique [8], [13] is utilised. The SPV array voltage or responsibility cycle can be perturbed using this way. For the former, a PI controller is required to generate a responsibility cycle for the Zeta converter, which will add complexity. Direct responsibility cycle control is therefore adapted to this project. Since

$$\frac{dP_{pv}}{dv_{pv}} = \frac{d(v_{pv} * i_{pv})}{dv_{pv}} = i_{pv} + v_{pv} * \frac{di_{pv}}{dv_{pv}} \cong i_{pv} + v_{pv} * \frac{\Delta i_{pv}}{\Delta v_{pv}}$$

Therefore, (equ) is rewritten as

$$\left. \begin{aligned} \frac{\Delta i_{pv}}{\Delta v_{pv}} &= -\frac{i_{pv}}{v_{pv}}; && \text{at mpp} \\ \frac{\Delta i_{pv}}{\Delta v_{pv}} &> -\frac{i_{pv}}{v_{pv}}; && \text{left of mpp} \\ \frac{\Delta i_{pv}}{\Delta v_{pv}} &< -\frac{i_{pv}}{v_{pv}}; && \text{right of mpp} \end{aligned} \right\}$$

For example: The controller selects which direction to perturb by comparing INC to instantaneous conductance as displayed in Fig and increasing/decreasing it accordingly. For example, the duty cycle is raised with a fixed perturbation size to the right of MPP until the direction is reversed. As soon as the operational point crosses the MPPT, the disturbance should cease. But in reality, the operating point is a bit off-kilter with respect to the MPP.

The controller takes longer to tune the MPP of the SPV array as the perturbation length decreases. MPPT and soft starting of BLDC motors can be achieved by maintaining a high-brow settlement between tracking duration and perturbation length. The initial value of the responsibility cycle will be 0 in order to ensure a smooth start. In addition, the smallest perturbation size (D=0.001) is chosen, which contributes to a soft start and minimises oscillations over the MPP.

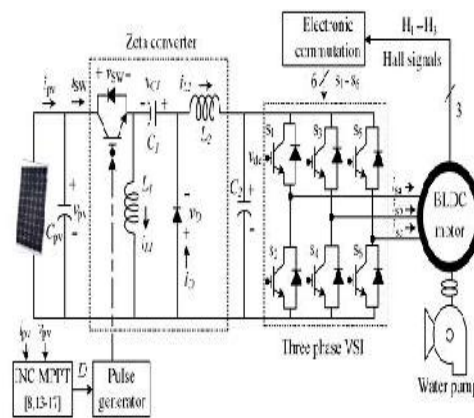

Fig3.1: Electronic Commutation of BLDC Motor

VSI with digital commutation is used to control the BLDC motor. The decoder and excellent judgement are both used in the digital commutation of BLDC motors to switch the currents flowing through the

windings in a preset series. Dc input is located at the centre of each phase voltage 120o symmetrically. The different combinations of three Hall-impact signals yield six switching pulses. A built-in encoder generates these three Hall-effect signals based on the rotor's position.

All six switching states are represented in Table II by a precise aggregate of Hall-impact signals for each specific variation of rotor function at any given interval of the technology of six switching states. The simplest two-switch operation results in 1200 conduction mode of operation, which reduces conduction losses. Besides this, the electronic commutation presents crucial frequency switching of the VSI, which eliminates PWM switching losses. A BLDC motor with an integrated encoder, manufactured by a motor energy agency, was selected for the suggested machine.

IV SIMULATION DESIGN:

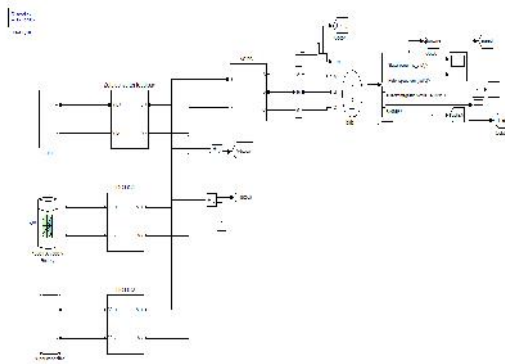

Fig 4.1: Simulation Block Diagram

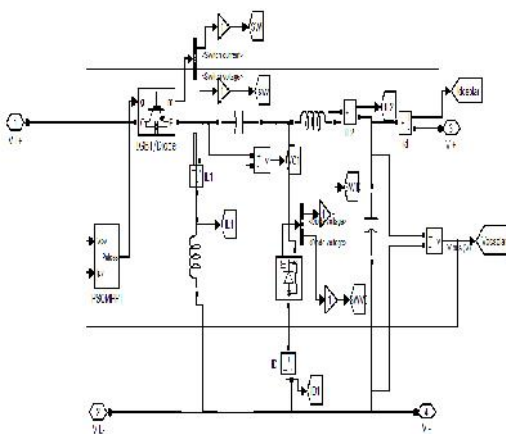

Fig 4.2: Simulation of Zeta Converter

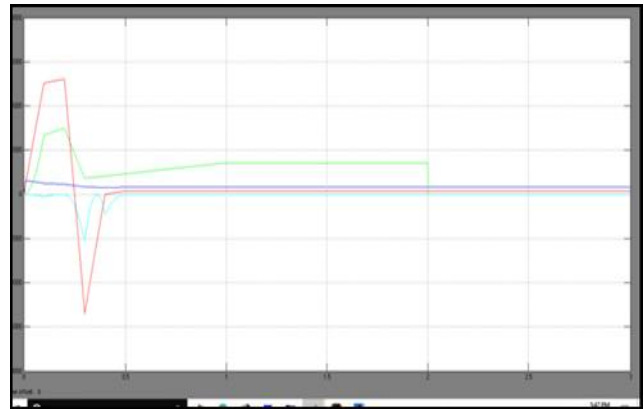

Fig 4.3: Power management curves for a step change of 1000 W/m² to 0 W/m² at 2 s

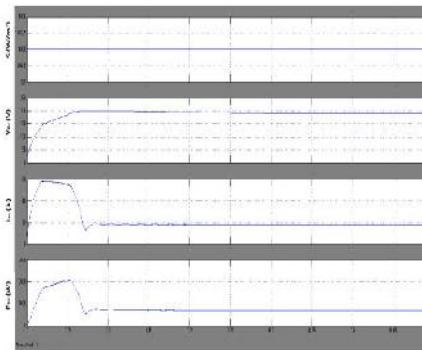

Fig 4.6 SPV array variables of Starting and steady-state performances of the proposed SPV array based zeta converter-fed BLDC motor drive for water pump.

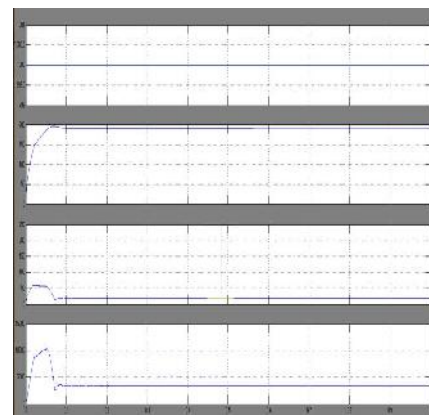

Fig 4.7 SPV array variables of dynamic performances of the proposed system

V CONCLUSION

The HESS zeta converter-powered BLDC drive has been proven to be a viable alternative to traditional energy sources. An increase in demand for Zeta converters will be seen in silent motor drives used for water pumping. To maintain a constant voltage, the HESS gadget uses an advanced power control mechanism. PSO-based MPPT under diverse atmospheric conditions, Zeta converter function, and dynamic device performance were all proven using the MATLAB / SIMULINK model. Other MPPT methods cannot compete with INC-conductance based MPPT approach for its superior performance in a wide range of static and dynamic air conditions. A successful control algorithm has been found, according to the results of the investigation.

REFERENCES

[1] B. Subudhi and R. Pradhan, "A comparative study on maximum power point tracking techniques for photovoltaic power systems," *IEEE Trans. Sustain. Energy*, vol. 4, no. 1, pp. 89–98, Jan. 2013.

[2] B. Bendib, H. Belmili and F. Krim, "A survey of the most used MPPT methods: conventional and advanced algorithms applied for photovoltaic systems," *Renew Sustain Energy Rev*, vol. 45, pp. 637–648, 2015.

[3] R. B. A. Koad, A. F. Zobaa and A. El-Shahat, "A novel MPPT algorithm based on particle swarm optimization for photovoltaic systems," *IEEE Trans. Sustain. Energy*, vol. 8, no. 2, pp. 468–476, Apr. 2017.

[4] V. K. A. Shankar, S. Umashankar, S. Padmanaban, M. S. Bhaskar, V. K. Ramchandaramurthy and V. Fedák, "Comparative study of photovoltaic based power converter topologies for pumping applications," *IEEE Conference on Energy Conversion (CENCON)*, Kuala Lumpur, Malaysia, pp. 174-179, 2017.

[5] B. Singh and V. Bist, "Power quality improvements in a zeta converter for brushless dc motor drives," *IET Sci. Meas. Technol.*, vol. 9, no. 3, pp. 351– 361, May 2015.

[6] V. Bist and B. Singh, "A brushless DC motor drive with power factor correction using isolated zeta converter," *IEEE Transactions on Industrial Informatics*, vol. 10, no. 4, pp. 2064-2072, Nov. 2014.

[7] M. H. Thagvee, M. A. M. Radzi, S. M. Moosavain, H. Hizam and M. Hamiruce, "A current and future study on non isolated DC-DC converters for

photovoltaic application," *Renew Sustain Energy Rev*, vol. 17, pp. 216- 227, Jan. 2013.

[8] R. Kumar and B. Singh, "BLDC motor-driven solar PV array-fed water pumping system employing zeta converter," *IEEE Transactions on Industry Applications*, vol. 52, no. 3, pp. 2315-2322, May-June 2016.

[9] S. K. Kollimalla, M. K. Mishra, A. Ukil and H. B. Gooi, "DC grid voltage regulation using new HESS control strategy," *IEEE Transactions on Sustainable Energy*, vol. 8, no. 2, pp. 772 781, April 2017.

[10] S. Kotra and M. K. Mishra, "A supervisory power management system for a hybrid microgrid with HESS," *IEEE Transaction*.