



## Thermal Analysis of Single Pass GRITH Weld for Different Materials

<sup>1</sup>Ramanaji Koneti <sup>2</sup>A.V.Sridhar <sup>3</sup>K.Mohan Krishna <sup>4</sup>J Hari Narayana Rao  
<sup>1</sup>M. Tech. Student, <sup>2</sup>Associate.Professor, <sup>3</sup>Assistant.Professor  
Dept Of ME, KITS , DIVILI  
<sup>4</sup>Reserch Scholar

### ABSTRACT:

Girth welds are the different types of arc welding processes applied in the joining of two pipes along the circumference during a phase construction of a pipeline depending on the ease of implementation and the environmental factor. They are used in making circumferential welds in pipeline and underground systems. They are used in the pipeline industry.

Here in this project we have designed a pipe which has be welded to a flange by single pass girth welding. Here we are going to consider two welding cases i.e. normal welding process and welding with an Al block under the welding portion. We are going to consider these two welding conditions for girth welding of the pipe made of two different materials i.e. Stainless Steel and Carbon steel alloy.

Thermal analysis is done to the product to study the weld behavior of the component. The Component is designed in CATIA V5 and Thermal analysis is carried out in ANSYS.

### 1. INTRODUCTION

#### GIRTH WELDS

Girth welds are the different types of arc welding processes applied in the joining of two pipes along the circumference during a phase construction of a pipeline depending on the ease of implementation and the environmental factor [1,2].

They are used in making circumferential welds in pipeline and underground systems. They are used in the pipeline industry in the following activities:[3,4]

- Main-line welding
- Tie-in welding
- Repair welding
- Fabrication welding

In girth welds, the welder has to make several passes to make it a perfect and sealed joint. The welder has to first make a root pass—the most difficult pass—at a specified speed. The second pass is a hot pass that increases the thickness of the fill. Finally, the third pass is the fill and cap pass that is made to finish the welding process by covering the joint [5,6].

- The mode of welding or the standards set for girth welds are determined by:
- The joint strength of the pipes based on the base material
- The joint strength based on the external conditions
- The method of pipe manufacturing process
- The pipe wall thickness and its diameter
- The length of the pipeline/cost
- The terrain and environmental factors
- The workmanship of the welder

### 2. DESIGN AND MATERIAL PROPERTIES

#### 2.1 MATERIAL PROPERTIES

- STAIN LESS STEEL  
THERMAL CONDUCTIVITY: 15.1W/m°C
- LOW CARBON STEEL  
THERMAL CONDUCTIVITY: 36W/mK
- CARBON STEEL ALLOY  
THERMAL CONDUCTIVITY: 50W/mk

#### 2.2 DESIGN

##### 2.2.1 Draft Model

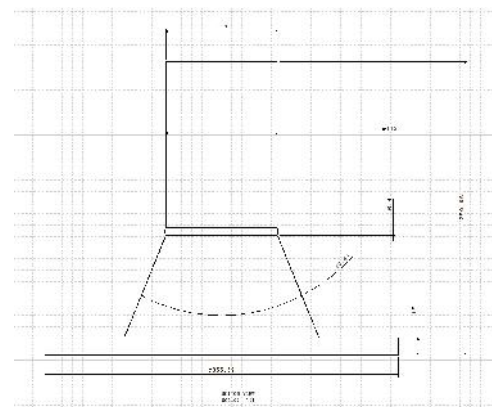

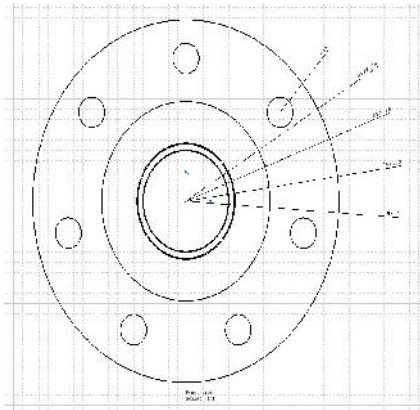

Fig. Drafting of pipe- flange assembly

### 2.2.2 3d Design Model

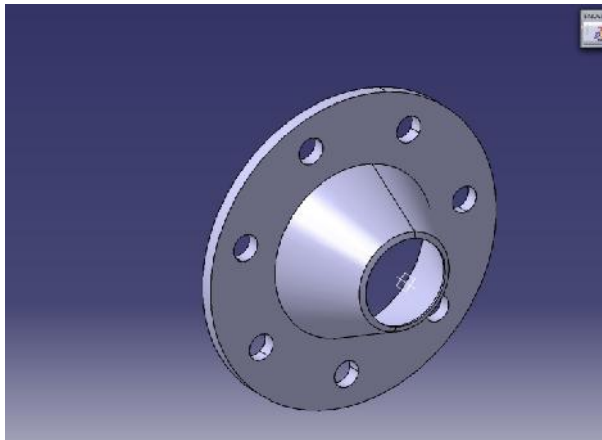

Fig1 Designing of flange

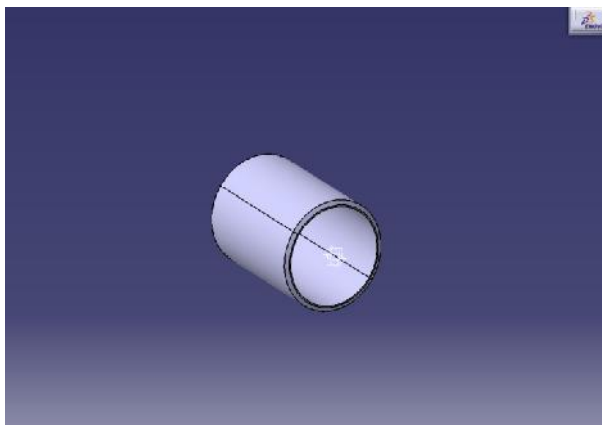

Fig2 Designing of pipe

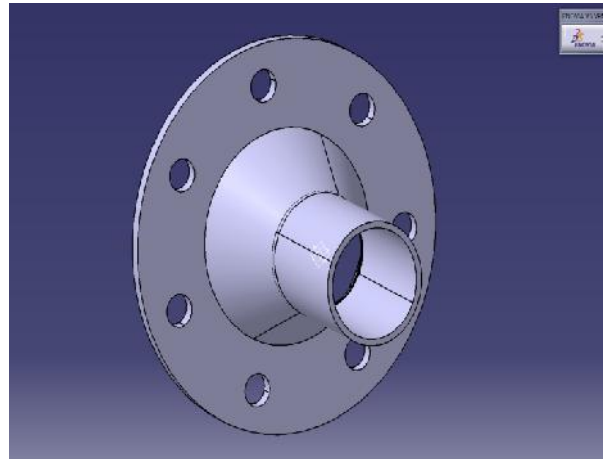

Fig3 Designing of pipe-flange assembly

## 3. ANALYSIS

### IMPORTED MODEL

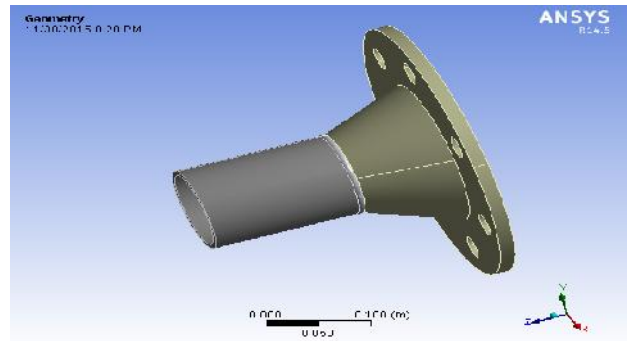

Fig4 Import model of directed welded stainless steel pipe

### MESH MODEL

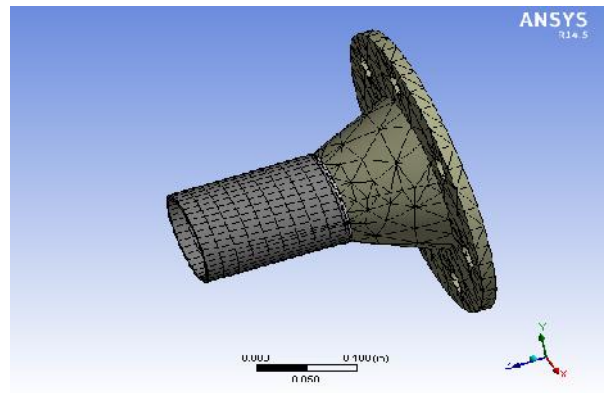

Fig5 Mesh model of directed welded stainless steel pipe

INPUT DATA

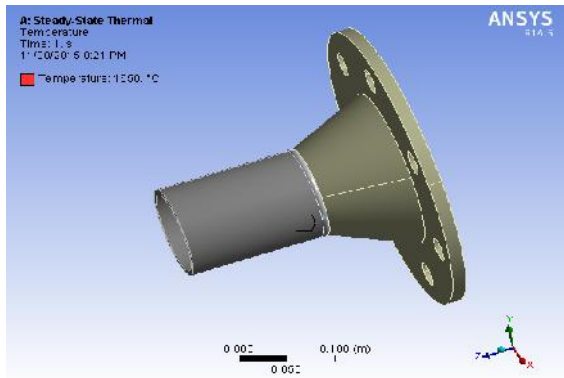

Fig6 Temperature input to model of directed welded stainless steel pipe

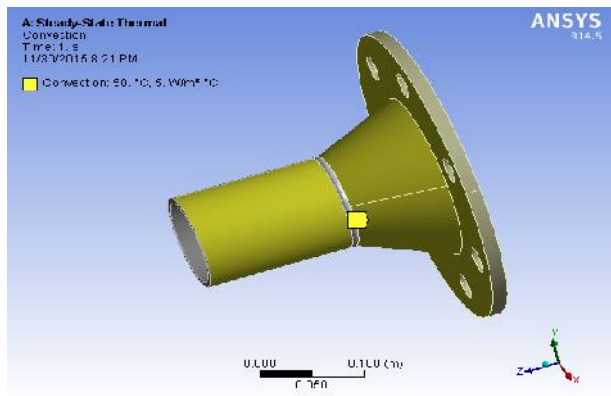

Fig7 Convection data input to model of directed welded stainless steel pipe

TEMPERATURE

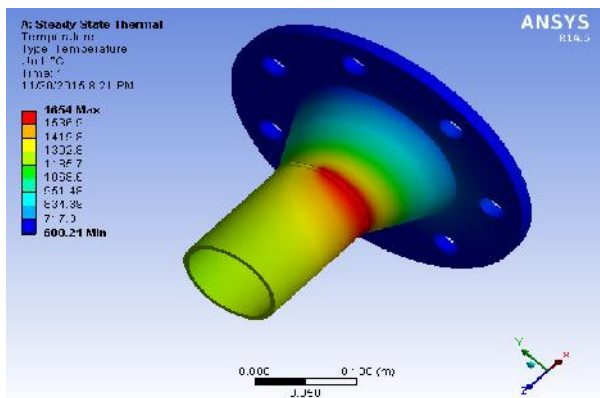

Fig8 Temperature of directed welded stainless steel pipe

TOTAL HEAT FLUX

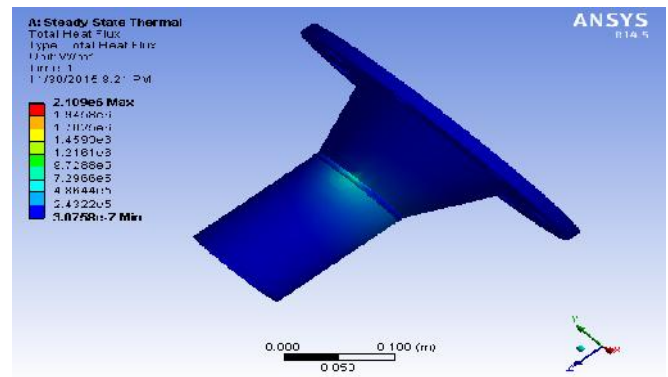

Fig9 Total heat flux of directed welded stainless steel pipe

DIRECTIONAL HEAT FLUX

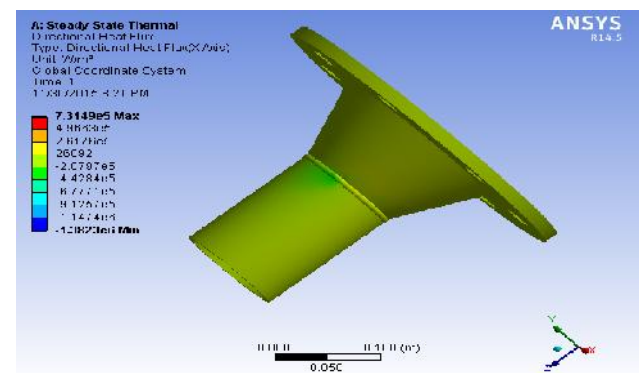

Fig10 Directional heat flux of directed welded stainless steel pipe

4. REPORT

Thermal Analysis Of Single Pass Girth Welding

		TEMPERATURE		HEAT FLUX		DIRECTIONAL HEAT FLUX	
		MIN	MAX	MIN	MAX	MIN	MAX
NORMAL WELD	STAINLESS STEEL	60.51	166.4	3.08E-07	2.19E+06	-	7.31E+05
	CARBO	1	1	3.0	1.8	-	6.2

	N STEEL ALLOY	038	653.1	8E-07	3E+06	1.16E+06	6E+05
AL BLOCK WELD	STAINLESS STEEL	243.29	174.65	0.00485	8.14E+06	-2.54E+06	6.92E+05
	CARBON STEEL ALLOY	570.75	734.43	0.001359	9.11E+06	-6.68E+06	1.89E+06

Table 1 Thermal Analysis result for Single pass girth welded pipe

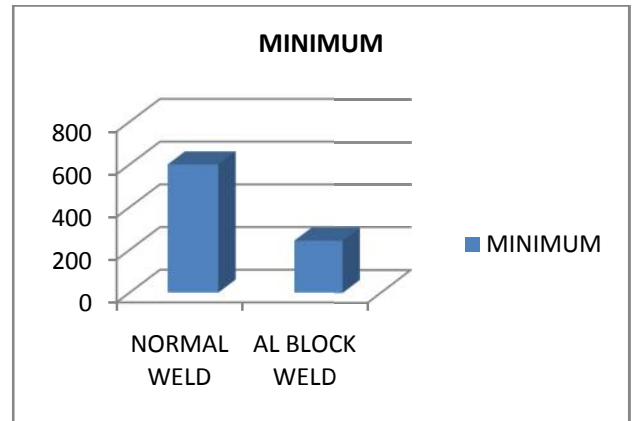

Graph1 : Min Temperature vs. Weld type for stainless steel pipe

**Thermal Analysis When Fluid Flows In This Pipe**

	TEMPERATURE		TOTAL HEAT FLUX		DIRECTIONAL HEAT FLUX	
	MIN	MAX	MIN	MAX	MIN	MAX
STAINLESS STEEL	790.15	800.11	0.003574	4988.5	-4702.7	4607.9
CARBON STEEL	790.15	800.04	0.002181	4333.9	-2874.6	2394.3

Table 2 Thermal Analysis result for Single pass girth welded pipe when fluid flows

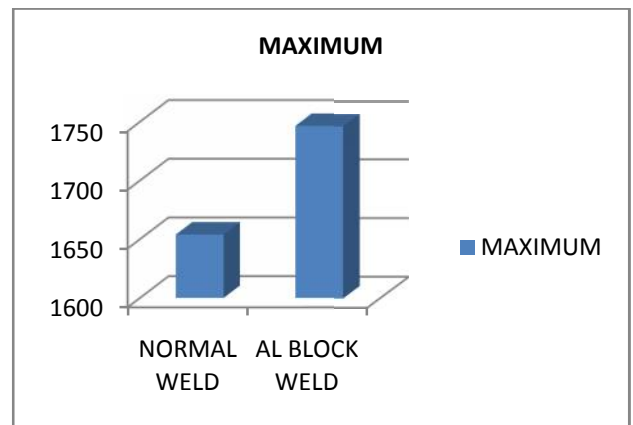

Graph2 : Max Temperature vs. Weld type for stainless steel pipe

**5. THERMAL ANALYSIS GRAPHS FOR STAINLESS STEEL PIPE**

TEMPERATURE

HEAT FLUX

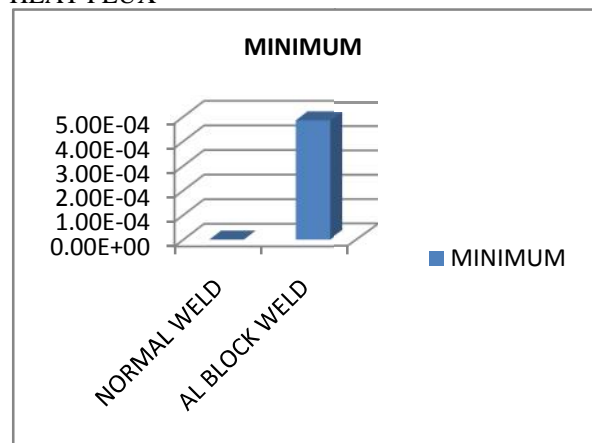

Graph3: Min Heat flux vs. Weld type for stainless steel pipe

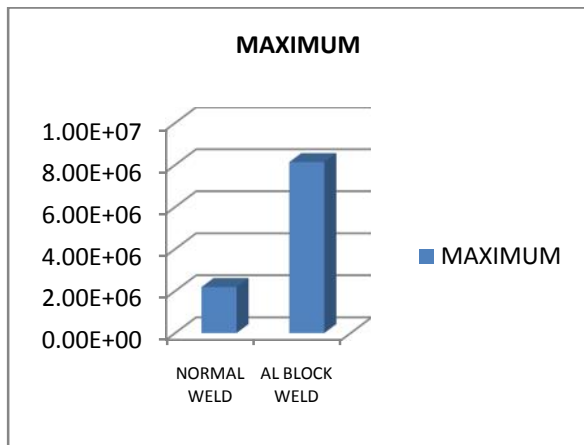

Graph4 Max Heat flux vs. Weld type for stainless steel pipe

DIRECTIONAL HEAT FLUX

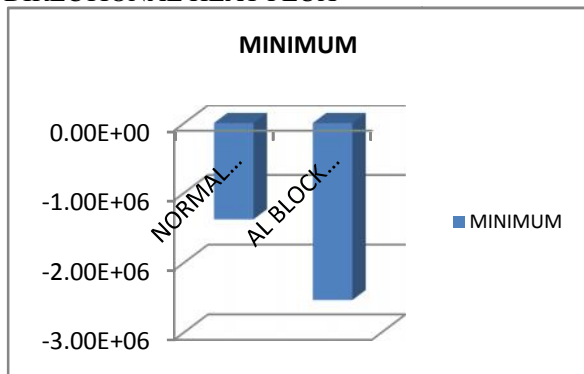

Graph5 Min Directional Heat flux vs. Weld type for stainless steel pipe

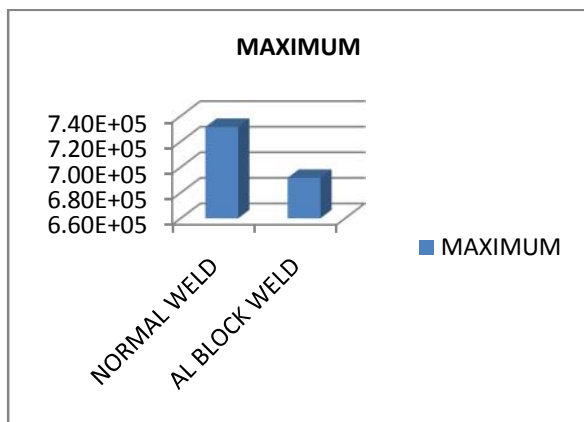

Graph6 Max Directional Heat flux vs. Weld type for stainless steel pipe

CONCLUSION

Here in this project we have designed a pipe which has been welded to obtain as a pipe, so here for welding purpose we are going to use low carbon steel. So here we have designed a pipe with stainless steel and welded with low carbon steel and the other model is manufactured with carbon steel and welded with low carbon steel alloy. And the same procedure is repeated in which an AL block is present under the welding portion. And thermal analysis is done to the product

As if we observe in the product which is welded under normal welding conditions and welded in which an AL block is located under the welding portion as to dissipate the heat easily. So as from the analysis, if we observe the tables and graphs, we can conclude that the pipe manufactured with carbon steel alloy and welded with low carbon in which an AL block is placed is the best material as the heat dissipation is very fast from the pipe while welding, so by this process the pipe can withstand high pressure and temperatures and give better life efficiency.

As from the analysis of the fluid flow from the pipe after welding, as if we observe the obtained tables and graphs, we can conclude that the pipe welded with low carbon and made with carbon steel is the best material as it is having the less heat flux on the product, so here we can conclude that this is the best material with best life output.

REFERENCES

- [1] Welding: Principles and Applications by Larry F. Jeffus, Cengage Learning, 01-Sep-1997 How To Weld by MBI, 2008
- [2] Pipe Welding Procedures by Hoobasar Rampaul, Industrial Press Inc., 2003
- [3] Aluminum Welding by N. R. Mandal, Woodhead Publishing, 01-Jan-2001
- [4] Trends In Welding Research: Proceedings of the 7Th International Conference by Stan A. David, ASM International, 2006
- [5] The Science and Practice of Welding by A. C. Davies, Cambridge University Press, 1992
- [6] Welded Joint Design by John G. Hicks, Woodhead Publishing, 1999